

Pull type grape harvester  
GREGOIRE G3.220

**GRE G OIRE**

PASSEZ À L'AVENIR\*

When maneuverability  
rhymes with pull type



**G3**

\*SHIFT TO THE FUTURE

More than 30 years  
of experience

---



During the years  
GREGOIRE has been  
able to develop its  
products to meet all  
of your harvesting  
requirements.



GREGOIRE offers a wide range of vineyard maintenance tools : sprayers, self-propelled or trailed harvesters for grapes and olives. The main qualities of the GREGOIRE products range are performance, reliability and low maintenance costs.

These key qualities make GREGOIRE the preferred supplier even for the most demanding end users.

The GREGOIRE product range is distributed and serviced via a worldwide network of distributors which are trained to provide professional advice and a top class after sales service.

Staying close to our customers allow us a great reactivity and a complete understanding of our customers' expectations

GREGOIRE has obtained a leading position in nearly all grape growing countries in the world.

Besides viticulture, GREGOIRE also developed harvest solution for olives.

Working with olive growers from the really beginning GREGOIRE is today one of major player in that industry.

**Choosing GREGOIRE means choosing the most reliable and highest quality supplier in mechanization of grapes and olives.**

## Summary

GREGOIRE G3.220	p.2
Frame	p.4
Control	p.6
Harvesting module	p.8
On board sorting system	p.10
Features	p.12

**1978, GREGOIRE  
GH Hydraulique**  
Fiabilité prouvée



**1989, GREGOIRE ARC  
Picking Head System**  
Has won worldwide recognition as the softest picking head on the market

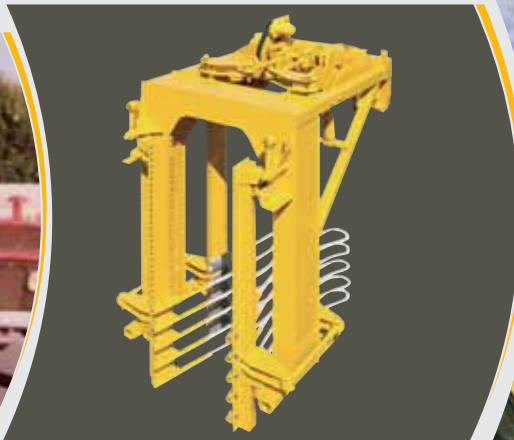

**2001, GREGOIRE 100-Series**  
Simple & Effective



**2009, GREGOIRE serie**  
Shift to the future







Pull type grape  
harvester G3.220

... Shift to the future

**G3**

Frame



When maneuverability  
and lightness  
meet together.



## User friendly, compact and lightness

- **User friendly** : easy driving operation even in hardest conditions
- **Compactness** : Compact size and reduced volume perfectly adapted to difficult harvest conditions
- **Lightness** : no soil compaction and easy management with low powered tractors
- **700 mm elevation** : Optimized slope correction for an easier work even in difficult situations

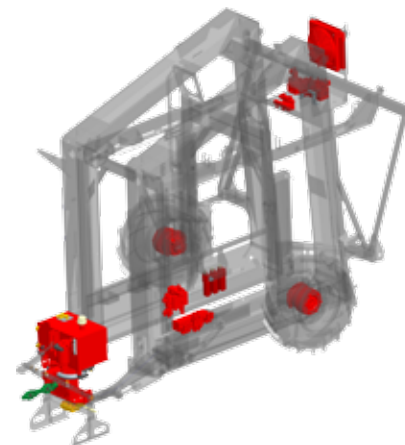

## Unrivaled transmission

- **820 cm<sup>3</sup> wheel motors** : high climbing capacities, easy work even in hardest conditions
- **Load Sensing hydraulic pump** : extra pressure absorption for a longer wheel motors life span
- **OVERboost** : Oil pressure booster for maximal climb capacities



## Easy and quick linkage

- **Integrated hydraulic power pack** : with support stand, quick fitting, easy access to the tractor three point linkage
- **Hydraulic pumps** : smart location, close to the three point linkage, fitted under the hydraulic tank
- **Hydraulic unit** : 70L oil capacity fitted on three point linkage for a reduced grape harvester weight



## Auto guiding

- **Automatic row following system** : no damage on vineyard
- **Picking tunnel self-alignment sensors** : automatic alignment over the row, for comfortable and safe driving operation : driver can focus on others tasks
- **Priority to manual control** : Operator may at any time take back control of the machine actuating the joystick

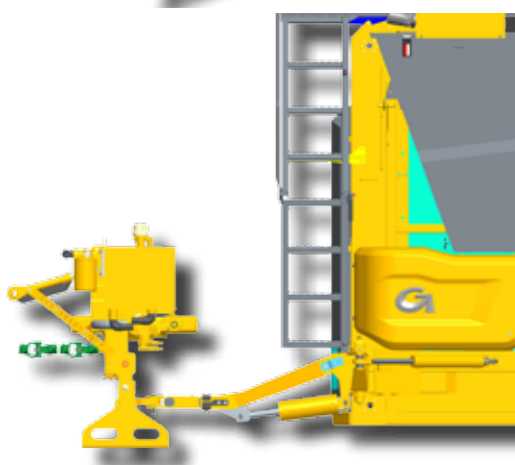

## Articulated and compact draw bar

- **Operated from the driver cab** : maximum maneuverability in every situation and perfect precision thanks to the joystick
- **Compact draw bar** : perfect visibility on the picking head tunnel



## Access and maintenance

- **Secured platform** : access to the upper part of the machine for easy settings and maintenance
- **Large size platform** : secured and facilitated interventions
- **Centralized greasing points** : easy and quick maintenance
- **Foldable ladder** : no damage to the vegetation, convenient access to the platform

## Controls



When long hours  
become shorter ...





## Optimized controls

- **Headlands sequencing** : Machine height sequencing (simultaneous or independent) and other machine function (picking head, conveying belt, fans on/off) when turning in headlands
- **Semi-automatic slope correction** : A simple push is sufficient to level the machine: ground levelling is optimized the machine works always flat
- **Front/Rear simultaneous elevation**



## Ergonomic and compact control box

- **Compact control console** : space saving, perfectly adapted to narrow cabs & specialized tractors
- **Perfect ergonomics** : easy to use and comfortable for long working hours
- **Controls integrated in the armrest** : more accurate and fatigue free



## MULTIdrive®, exclusive joystick

- **Pivot mounted joystick** : the joystick controls three times more functions (GREGOIRE patent)
- **Total control** : includes all machine functions ( Draw bar, height, slope, picking head, headlands sequencing, bins ..)
- **Auto level** : a special button controls the semi-automatic slope correction whatever the joystick position

*Experience same driving sensation as a self-propelled machine*



## TOUCHpad, tactile and color screen

- **Color screen** : easy to read out the centralized data so you can focus on driving the harvester
- **Centralized data screen** : a complete display of most of the harvester functions in one glance which means more efficiency and security for the operator
- **Intuitive drawings** : easy understanding and use
- **Easy set up** : quick navigation, 3 possible ways : tactile, contactors or scroll



## User friendly display

- **Real time display** : all components speed are displayed in real time for a perfect control of your harvest
- **Slope indicators** : keep control on your harvester inclination
- **Bins filling gauge with color screen display** : color codes allows an easy and fast reading
- **Automatic camera management** : during dumping operations color camera is automatically display on the TOUCHpad screen



## More & more ...

- **Setting recording** : settings are stored and can be retrieved back quickly
- **Plot recording** : picking head hours , number of hectares picked, working hours
- **Data transfer** : data can be recorded and transferred to a laptop or desktop computer

Harvesting module

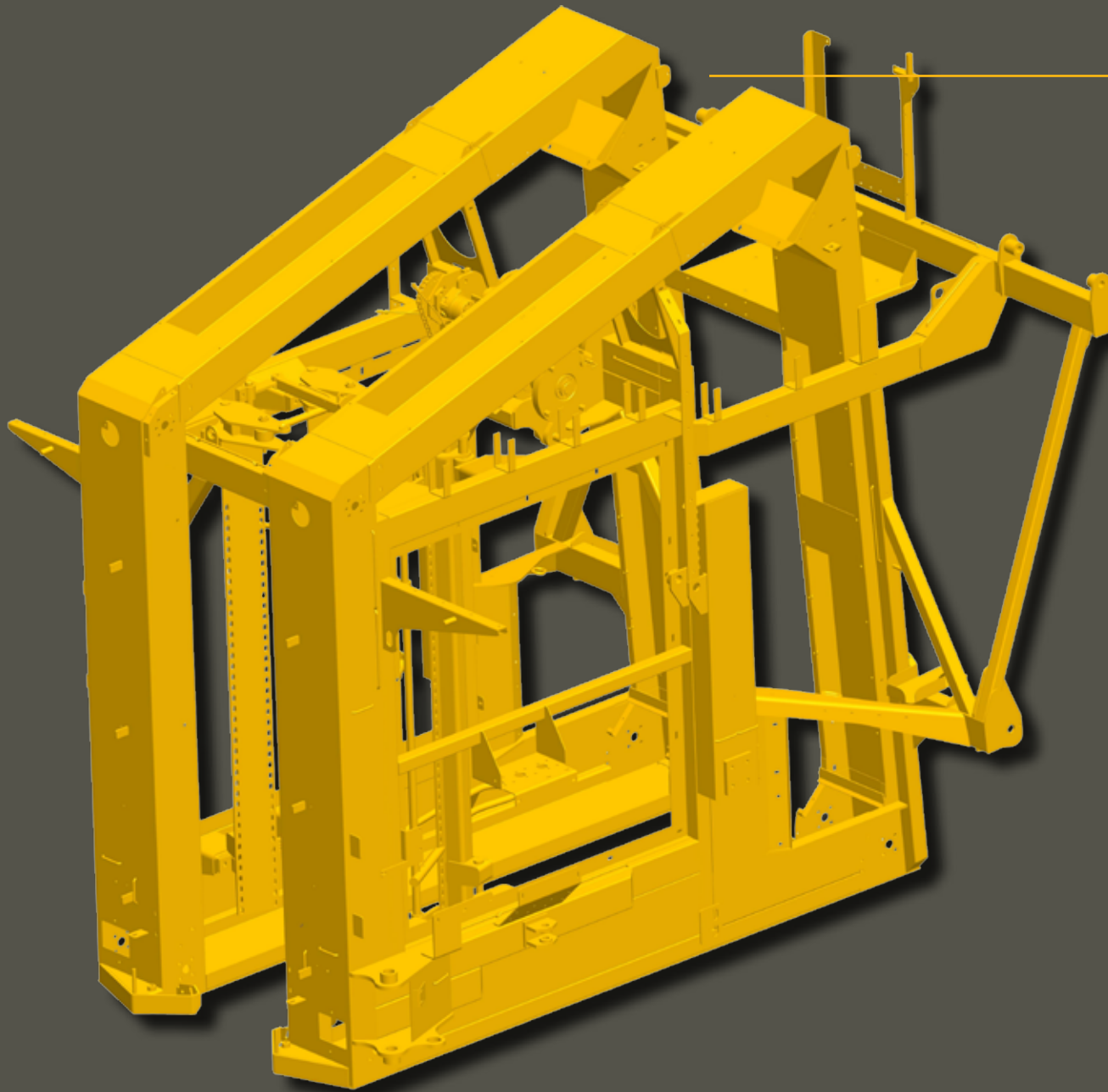

When technology  
contributes to quality



## Hydraulic pinch adjustment

- **Eccentric bloc rotation** : no friction between parts, great reliability
- **Adjustable from the cab** : easy adaptation to all types of vines
- **Large width setting range** : always get the right setting to every harvesting conditions
- **New compact eccentric bloc** : reduced size & weight for a lighter machine

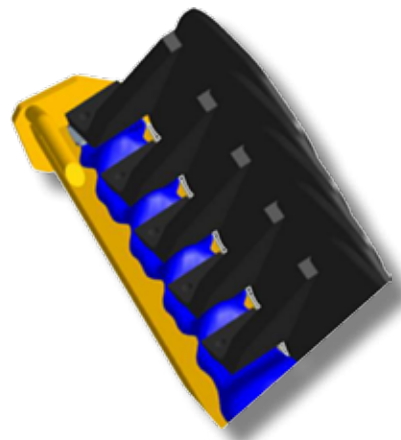

## Optimized catching area

- **Pneumatic catcher trays system** : return in position thanks to pneumatic stiffeners, pressure is adjustable to respect all type of vines
- **Pneumatic cushion** : quick and perfect adaptation to vine types and scale wearing
- **Picking height only 15 cm from the bottom** : GREGOIRE can pick grapes at 15 cm from the ground (the lowest in the market), no losses of grapes and no grapes that get left behind
- **Important water tightness, 2200mm** : high work speed, no loses on the ground

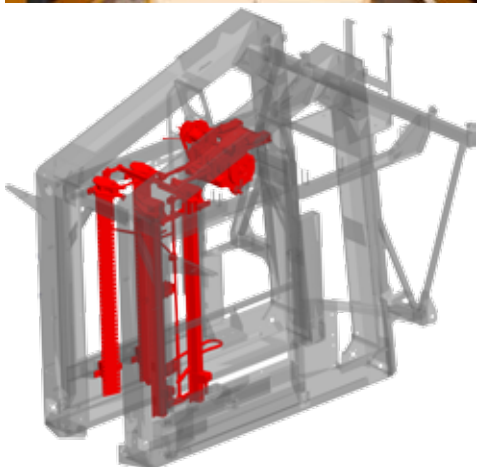

## Optimized driving system

- **Two picking posts** : double driving system, uniform checking cinematic for a great picking quality and a total respect of your vines
- **Two shakers support system** : low shaking frequency, high work speed
- **Mounted on heavy duty silent blocks** : no vibrations and extremely reliable



## Conveying : efficiency and respect of the grape

- **Supple belt driving system** : made by pendulum system, automatic tensioning depending on yields, belt respect in case of sudden tension
- **Simple belt routing** : no trituration, no blockage risks, open system for a total respect of your grapes
- **Exclusive GREGOIRE belt** : long lasting, reliable and repairable

## ARC shakers : Soft pick & efficiency

- **Adjusting the active zone** : quick and accurate setting of the shakers position for a perfect adaptation to every picking conditions
- **Exclusive shape** : ARC shape assures that the rods are longer in contact with the fruit bearing zone and also pick very well around the intermediate posts
- **Exclusive material** : long lasting and very hard wearing



## Maximal cleaning, minimal loses

- **Bottom cleaning fans and vertical cane extractors** : Cleaning and wood extraction right after grapes are picked, no juice loss no blockage risks
- **Top fan on option** : maximum cleaning efficiency even at high speed
- **All settings available from drivers cab** : all functions and cleaning fans speed are operated from the driver cab

Sorting system



An unequalled  
harvest quality



# simplicity for a top quality sample



## Sorting chain

- **A large sorting surface** : grapes are sorted without trituration
- **Plastic chain** : oxidation free, reliable and low wear
- **Modular chain** : minimum maintenance costs
- **Rounded shape** : grapes are not damaged by sharp surfaces



## Rotor

- **Soft fingers** : minimum risk of maceration and serious blockages
- **Helical assembly of fingers** : drives the leaves and the stems out of the sorting module
- **Soft fingers are mounted as monobloc** : good resistance against wear and tear which means lowering the cost of maintenance
- **Integrated ejection system** : no recycling of MOG and no accumulation of MOG thanks to the integrated scraper at the end of the rotor

## Remove from service

- **On-off hydraulic disengagement** : easy and quick adaptation in every vineyard condition
- **Complete disengagement when out of service** : no parts are moving when the system is out of service that means no extra wear of the components
- **Direct into the bin** : the CLEANTECH system is lifted out of the way, the harvest is transported directly from the feeding auger into the bin



# from the vine to the tank!!!

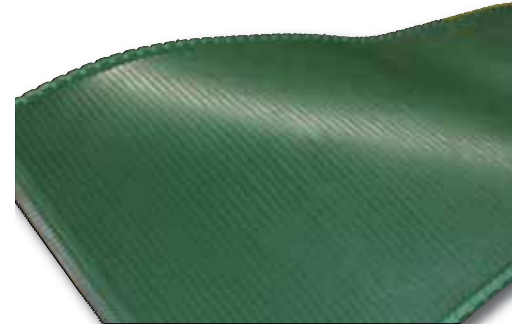

## Conveyor belt

- **Just under the sorting chain** : reduced drop height, which limits maceration
- **Exclusive pattern of the sorting belt** : grooved pattern that allows an equal berry flow and petioles onto the roller system



## Roller system

- **Curved shape of rollers** : allows a free passage of the individual berries which reduces the risk of berry rupture and trituration
- **Dynamic roller profiles** : thanks to the dynamic profiles, petioles and stems are transported horizontally straight out of the sorting system
- **Exclusive roller shape** : the perfect shape to pick up stems and petioles



## Vario®

- **Distance between the rollers can be modified** : you can vary the distance between the rollers to accommodate the size of the grapes
- **Centralized adjustment** : one single movement and roller distance can be adjusted
- **Exclusive GREGOIRE patent** : the Vario principle – variation of distance between the rollers – is patented by GREGOIRE

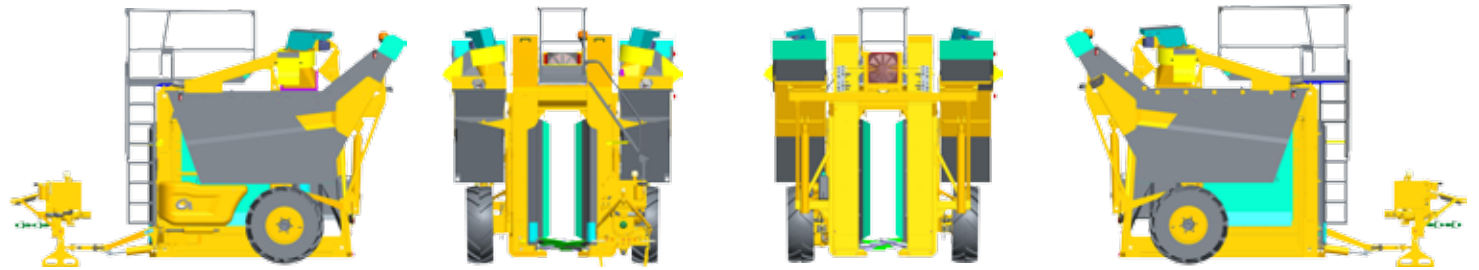

	Total length	Total width	Total height (conveyor on the ground)	Bins height (conveyor on the ground)	Width at bins level	Wide	Wide at wheels	Height axis dump bins (conveyor on the ground)	Deflection of leg
G3.220 two 12HL bins	4500	2710	3320	2665	2640	2185	2550	2255	700
G3.220 two 15HL bins	4500	2950	3320	2665	2880	2185	2550	2255	700

# Equipement

G3.220	
<b>For plantations</b>	
Minimum width	1,50m
Height maximum	1,95m
<b>Linkage</b>	
Three point	Standard
Tri-axis	-
<b>Transmission</b>	
Wheel drive	Standard
Wheel drive operated from control box	Standard
Hydraulic lifting/lateral slope correction	700mm / 25%
Tyres	360/70R24
<b>Hydraulic</b>	
On board hydraulic power pack	Standard
Tractor hydraulic needs	On 2 fans version
Oil tank capacity	70L
Filtration system	Pressure + return
<b>Harvesting module</b>	
Shakers	14 Alum. support, height and number setting
Réglage de pincement	Standard
Number of catcher trays	2x18
Water tightness length	2200mm
Soil clearance catcher tray	Less than 15cm
Conveyor width	320mm
Distance between conveyors	650mm
Conveying speed	Adjustable and reversible
Conveyor alarm	Standard
Central greasing points	Standard

G3.220	
<b>Cleaning</b>	
Bottom cleaning fans	Standard
Vertical cane extractors	Depend on version
Top cleaning fans	Depend on version
<b>Cleantech®</b>	Depend on version
<b>Vario®</b>	Depend on version
<b>Bins</b>	
Bin capacity	2400L standard / 3000L option
Discharge height	3000mm
Emptying method	Rear

\*Specifications are indicative, in order to constantly improve its products, GREGOIRE reserves the right to modify specifications without notice

\*\* This literature has been compiled for worldwide circulation. While general information, pictures and descriptions are provided, some illustrations and text may include product, options and accessories NOT AVAILABLE in all regions.

\*\*\* The equipment complies with European Directives 2002/44 / EC and 2003/10 / EC

# GREGOIRE know-how to serve your vineyard

With over 30 years experience in the mechanization of vineyards, GREGOIRE offer a complete range dedicated to grape and olive harvesting and spraying.

## GREGOIRE G7 & G8



## GREGOIRE SPEEDFLOW & Progress boom



## GREGOIRE G10.380



### **GREGOIRE**

89, avenue de Barbezieux  
CS70213 Châteaubernard  
FR-16111 Cognac Cedex

Tel. +33 (0)5 45 82 23 49  
Fax. +33(0)5 45 82 94 43

[contact@gregoiregroup.com](mailto:contact@gregoiregroup.com)  
[www.gregoire.fr](http://www.gregoire.fr)  
[facebook.com/gregoirefrance](https://facebook.com/gregoirefrance)

# **GREGOIRE**

The characteristics of our machines are indicative and we reserve the right to modify them without notice.

G3\_GB 201409